

From 4'245 to 8'370 MW: Tucuruí Power Plant and Substation benefit from ABB's solutions



- ▲ Comprehensive, modular schemes for retrofit as well as extension
- ▲ Protection and monitoring in the Power Plant with REG 216 / REB 500 / REL 316*4 systems complemented by SMS 530
- ▲ Integrated numerical automation and protection system for the 500 kV Substation

Tucuruí Power Plant, owned by Centrais Elétricas do Norte do Brasil S.A. (Eletronorte), is one of the world's largest hydro power plants. It's present extension adds 11 generators to the existing 12 units raising the output from 4'245 MW to an impressive 8'370 MW. The utility Eletronorte is responsible for the generation and transmission of electrical energy in the Amazon region, covering about 60% of Brazil's territory. Besides supplying mining and metallurgical industries, it also distributes energy to Manaus and Boa Vista, the capital cities of Amazonas and Roraima states.

To complement the extension process of the project, Eletronorte decided to retrofit the protection systems of the existing power plant and substation, and to implement a new numerical substation automation system. This called for a modern overall concept with homogenous technical solutions for both the extension and the retrofit part. Eletronorte entrusted ABB with this important project.

Protection and monitoring of the Power Plant

Numerical REG 216 systems protect the generators and transformers, whereas REL 316*4 are used for differential protection of the short lines to the substation. A REB 500 system with 18 bay units protects the 6 T-zones with 2 generator feeders and an outgoing line each. Inductive 650 disturbance recorders as well as all these IEDs are connected to the SMS 530 station monitoring system providing complete online disturbance data collection and evaluation, settings, etc. The power plant control system is provided with alarms, trip and status information via serial links to the generator feeder control unit.

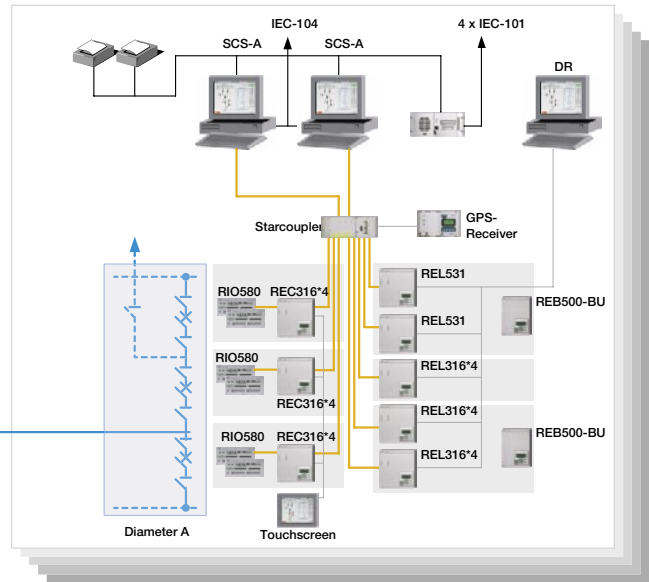
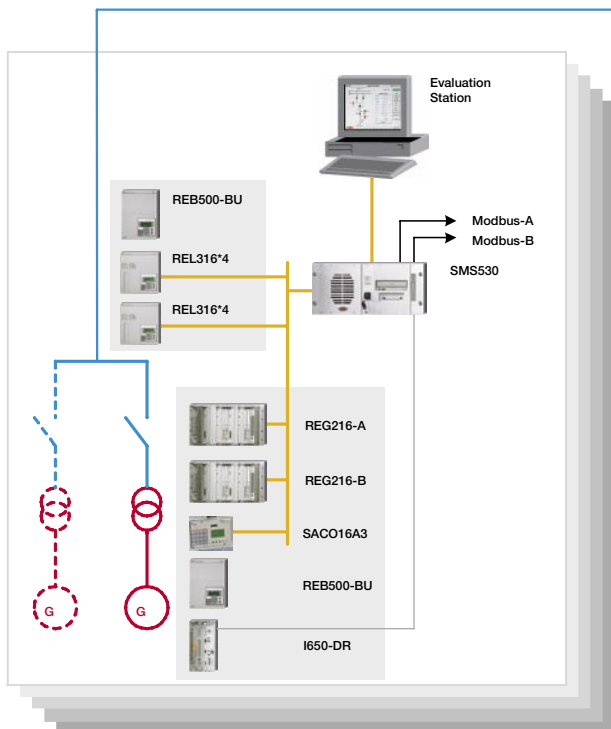

Automation of the 500kV substation

The control and protection of the 1½ breaker configuration with 6 diameters for the retrofit and 5 diameters for the extension part, is being handled efficiently with ABB solutions:

- The protection systems used are type REL531 for the series-compensated transmission lines and REB500 for busbar and breaker failure. The REB500 system with centralized installation for the retrofit ensures reuse of the existing cabling. The decentralized REB500 installation in the newly built substation with 5 diameters for the extension, in turn, offers substantial savings in cabling.
- On bay level the automation system comprises three REC 316*4 numerical control terminals per diameter. The I/Os are handled by RIO 580 remote I/O units, which provide e.g. the information for bay interlocking to all control terminals. A Touch Screen supports the operator with local backup control and monitoring of all switching devices in the diameter.
- On station level the automation system consists of operator places in a hot standby configuration. These provide efficient control and monitoring of the entire substation as well as the communication to the control center for remote control.

For more information please refer to the responsible ABB sales engineer for your country or to the address mentioned below



ABB Switzerland Ltd
Utility Automation Systems
Brown Boveri Strasse 6
CH-5400 Baden/Switzerland

Phone +41-58-585 77 44
Fax +41-58-585 55 77
e.Mail substation.automation@ch.abb.com

www.abb.com/substationautomation

The IndustrialIT wordmark and all mentioned product names in the form XXXXXXIT are registered or pending trademarks of ABB.