

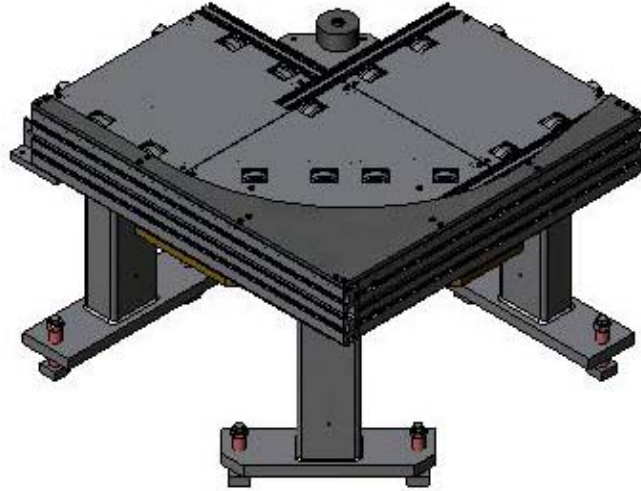

MS-7 800mm Pallet Corner Unit

Main Applications: Engine, Axle, Transmission Assembly



- Description:**
- Pallet corner unit to transport 800mm wide pallet 90° around corner
- Equipment:**
- MS-7 transport section
 - 45° Coupling to slave power from driven side of conveyor
 - Upper and lower deckplate covers
 - Three (3) leg sets (parametric design allows for 400mm - 800mm height)
- Customer Benefits:**
- Small unit profile
 - Global standard available from all ABB PTA lead centers
- Global Code:** S0700-310-80 Version: A



MS-7 800mm Pallet Corner Unit

Process Parameters

Name	Values	Units	Description
Rotation:	90 (default); n/a (min); 360 (max);	degrees	Angular rotation capability of the unit
Conveyor speed:	15 (default); 2 (min); 18 (max)	m/min.	Operating speed limits of this conveyor
Standard length:	1 (default)	Meters	inches

Design Parameters

Name	Values	Units	Description
None			

Reference Projects:
301351; 301359

ABB Inc.
1250 Brown Road
Auburn Hills, Michigan 48326
T/ 248-393-4600
F/ 248-393-4603

ABB Automation Technologies AB
Powertrain
Omformargatan 18
SE-72137 Västerås
Sweden
T/ +46-21-3600-400
F/ +46-21-3600-450

ABB Engineering Ltd.
31 Industrial Building
Fu Te Dong San Road
Waigaoqiao FTZ, Pudong
Shanghai, P. R. China 200131
T/ +86-21-6105-6666
F/ +86-21-6105-6667

www.abb.com/robotics

ABB Inc.

