

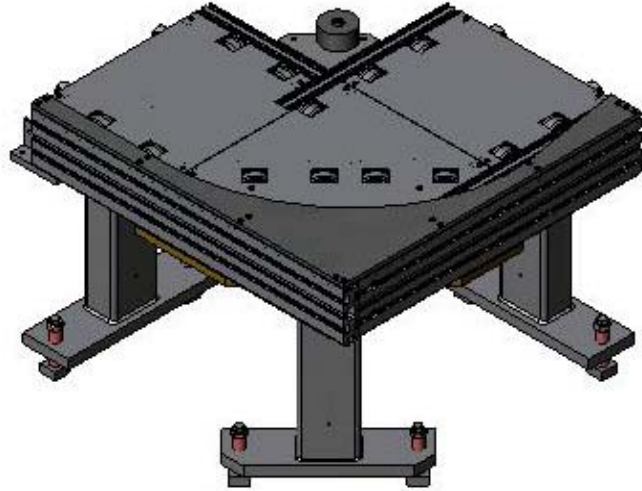

# MS-7 600mm Pallet Corner Unit

Main Applications: Engine, Axle, Transmission Assembly



**Description:**

- Pallet corner unit to transport 600mm wide pallet 90° around corner

**Equipment:**

- MS-7 transport section
- 45° Coupling to slave power from driven side of conveyor
- Upper and lower deck plate covers
- Three (3) leg sets (parametric design allows for 400mm - 800mm height)

**Customer  
Benefits:**

- Small unit profile
- Global standard available from all ABB PTA lead centers

**Global Code:**

S0700-310-60

Version: A



# MS-7 600mm Pallet Corner Unit

## Process Parameters

Name	Values	Units	Description
Rotation:	90 (default); n/a (min); 360 (max);	degrees	Angular rotation capability of the unit
Conveyor speed:	15 (default); 2 (min); 18 (max)	m/min.	Operating speed limits of this conveyor
Standard length:	1 (default)	Meters	inches

## Design Parameters

Name	Values	Units	Description
None			

Reference Projects:  
301351; 301359

ABB Inc.  
1250 Brown Road  
Auburn Hills, Michigan 48326  
T/ 248-393-4600  
F/ 248-393-4603

ABB Automation Technologies AB  
Powertrain  
Omformargatan 18  
SE-72137 Västerås  
Sweden  
T/ +46-21-3600-400  
F/ +46-21-3600-450

ABB Engineering Ltd.  
31 Industrial Building  
Fu Te Dong San Road  
Waigaoqiao FTZ, Pudong  
Shanghai, P. R. China 200131  
T/ +86-21-6105-6666  
F/ +86-21-6105-6667

[www.abb.com/robotics](http://www.abb.com/robotics)

**ABB Inc.**

